



Advanced Card Systems Ltd.
Card & Reader Technologies

ACR32 MobileMate

Technical Specifications V1.03





Table of Contents

1.0.	Introduction	3
1.1.	Secure Card Reader.....	3
1.2.	Ingenious Design	3
1.3.	Ease of Integration.....	3
2.0.	Features	4
3.0.	Supported Card Types.....	5
3.1.	Magnetic Cards.....	5
3.2.	MCU Cards	5
3.3.	Memory-based Smart Cards.....	5
4.0.	Typical Applications	6
5.0.	Technical Specifications	7



1.0. Introduction

ACR32 MobileMate Card Reader is the ideal tool you can use with your mobile device. With the combination of two card technologies in one, it provides its user the flexibility to use magnetic stripe cards and smart cards without additional cost. ACR32 MobileMate seamlessly unites card reader functionality with mobility which allows you to access secure applications anytime, anywhere.



1.1. Secure Card Reader

ACR32 MobileMate is a reliable card reader that uses AES-128 encryption algorithm and DUKPT Key Management System for a secure transaction. It is capable of reading both high-coercivity and low-coercivity magnetic cards that conform to ISO 7810 and ISO 7811 standards. Also, it supports ISO 7816 Class A, B, and C smart cards (5 V, 3 V, and 1.8 V), microprocessor cards with T=0 and T=1 protocol, and common memory cards in the market which makes it an ideal device for a broad range of solutions such as e-Banking and e-Payment.

1.2. Ingenious Design

ACR32 MobileMate is specifically designed to be brought anytime, anywhere. With its rechargeable Lithium-ion battery as its power supply and standard 3.5 mm audio jack interface, it allows ACR32 MobileMate to be integrated impeccably with most smartphones and tablets available in the market.

1.3. Ease of Integration

ACR32 MobileMate can be easily integrated with any mobile device running the Android™ platform with versions 2.0 and later, and iOS platform with versions 5.0 and later. Additionally, ACR32 MobileMate becomes a PC-linked smart card reader when connected to a computer – allowing it to work with operating systems such as Windows®, Linux®, or Mac OS®.



2.0. Features

- 3.5 mm Audio Jack Interface
- USB Full Speed Interface
- Power Source:
 - Powered by a Lithium-ion battery (rechargeable through Micro-USB Port)
 - USB Powered (PC-linked mode)
- Plug and Play – CCID support brings utmost mobility
- Smart Card Reader:
 - Supports ISO 7816 Class A, B, and C (5 V, 3 V, 1.8 V) cards
 - Supports microprocessor cards with T=0 and T=1 protocol
 - Supports memory cards
 - Supports PPS (Protocol and Parameters Selection)
 - Features Short Circuit Protection
- Magnetic Stripe Card Reader:
 - Reads up to two tracks of card data
 - Capable of bi-directional reading
 - Supports AES-128 encryption algorithm
 - Supports DUKPT Key Management System
 - Supports ISO 7810/7811 magnetic cards
 - Supports Hi-coercivity and Low-coercivity magnetic cards
 - Supports JIS1 and JIS2
- Application Programming Interface:
 - Supports PC/SC
 - Supports CT-API (through wrapper on top of PC/SC)
- Supports Android™ 2.0 and later¹
- Supports iOS 5.0 and later²
- Compliant with the following standards:
 - EN 60950/IEC 60950
 - ISO 7816
 - ISO 7811
 - EMV™ Level 1 (Contact)
 - PC/SC
 - CCID
 - CE
 - FCC
 - RoHS 2
 - REACH
 - VCCI (Japan)
 - KC (Korea)
 - Microsoft® WHQL

¹ Uses an ACS-defined Android Library; PC/SC and CCID support are not applicable

² Uses an ACS-defined iOS Library; PC/SC and CCID support are not applicable

Note: Visit www.acs.com.hk for the list of supported devices.



3.0. Supported Card Types

3.1. Magnetic Cards

ACR32 MobileMate operates with ISO 7810/7811 magnetic cards with High Coercivity and Low Coercivity.

3.2. MCU Cards

ACR32 MobileMate operates with ISO 7816 MCU cards following either the T=0 or T=1 protocol.

3.3. Memory-based Smart Cards

ACR32 MobileMate works with several memory-based smart cards such as:

- Cards following the I2C bus protocol (free memory cards) with maximum 128 bytes page with capability, including:
 - Atmel®: AT24C01/02/04/08/16/32/64/128/256/512/1024
 - SGS-Thomson: ST14C02C, ST14C04C
 - Gemplus: GFM1K, GFM2K, GFM4K, GFM8K
- Cards with secure memory IC with password and authentication, including:
 - Atmel®: AT88SC153 and AT88SC1608
- Cards with intelligent 1 KB EEPROM with write-protect function, including:
 - Infineon®: SLE4418, SLE4428, SLE5518 and SLE5528
- Cards with intelligent 256-byte EEPROM with write-protect function, including:
 - Infineon®: SLE4432, SLE4442, SLE5532 and SLE5542
- Cards with '104' type EEPROM non-reloadable token counter cards, including:
 - Infineon®: SLE4406, SLE4436, SLE5536 and SLE6636
- Cards with intelligent 416-bit EEPROM with internal PIN check, including:
 - Infineon®: SLE4404
- Cards with Security Logic with Application Zone(s), including:
 - Atmel®: AT88SC101, AT88SC102 and AT88SC1003



4.0. Typical Applications

- e-Healthcare
- e-Purse and Loyalty
- Mobile Banking and Payment



5.0. Technical Specifications

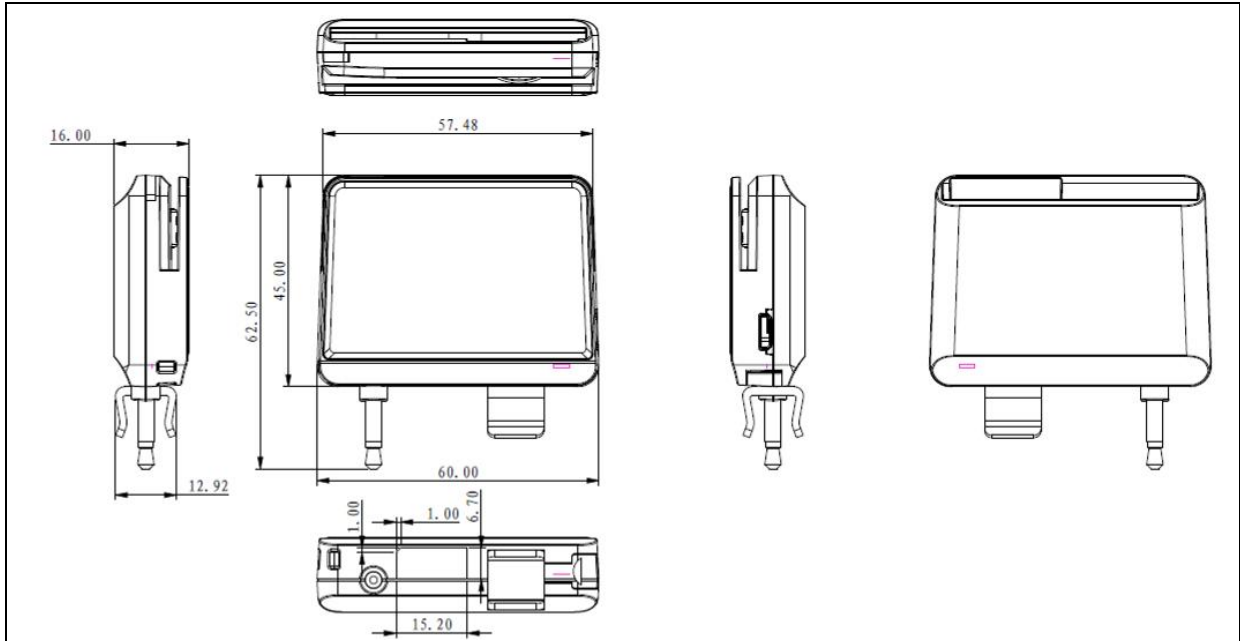

Physical Characteristics

Dimensions 60 mm (L) x 45 mm (W) x 16 mm (H)
Weight..... 30.5 g (with battery)
Color White

Audio Jack Communication Interface

Protocol..... Bi-directional Audio Jack Interface
Connector..... 3.5 mm 4-pole Audio Jack
Speed..... Max. 2.6 Kbps
Power Source..... Rechargeable Lithium-ion Battery (charging through USB)

USB Host Interface

Protocol..... USB CCID
Connector Type..... Micro-USB
Power Source..... From USB port
Speed..... USB Full Speed (12 Mbps)
Supply Voltage 5 V
Cable Length..... 1 m, Detachable

Contact Smart Card Interface

Number of Slot 1 Full-sized Card Slot
Standard ISO 7816 Class A, B, and C (5 V, 3 V, 1.8 V)
Protocol..... T=1; T=1; Memory Card Support
Supply Current Max. 50 mA
Smart Card Read/Write Speed..... 9.6 Kbps – 600 Kbps
Short Circuit Protection (+5) V/GND on all pins
Clock Frequency 4.8 MHz
Card Connector Type..... ICC Slot 0: Contact
Card Insertion Cycles..... Min. 100,000

Magnetic Card Interface

Standard ISO 7810/7811 Hi-Co and Low-Co Magnetic Cards
..... JIS1 and JIS2
Card Swipe Speed Max. 10 in/s
Card Swipe Cycles..... Min. 500,000

Application Programming Interface

PC-linked Mode..... PC/SC
..... CT-API (through wrapper on top of PC/SC)

Operating Conditions

Temperature 0 °C – 50 °C
Humidity Max. 90% (non-condensing)
MTBF 300,000 hrs



Certifications/Compliance

EN 60950/IEC 60950, ISO 7816, ISO 7811, USB Full Speed, EMV™ Level 1 (Contact), PC/SC, CCID, CE, FCC, RoHS 2, REACH, VCCI (Japan), KC (Korea), Microsoft® WHQL

Device Driver Operating System Support

Windows® XP, Windows Vista®, Windows® 7, Windows® 8, Windows® 8.1, Windows® 10
Windows® Server 2003, Windows® Server 2008, Windows® Server 2008 R2, Windows® Server 2012, Windows® Server 2012 R2, Windows® Server 2016
Linux®, Mac OS®, Solaris, Android™ 2.0 and later, iOS 5.0 and later



Android is a trademark of Google Inc.
Atmel is registered trademark of Atmel Corporation or its subsidiaries, in the US and/or other countries.
EMV is a registered trademark or trademark of EMVCo LLC in the United States and other countries.
Infineon is a registered trademark of Infineon Technologies AG.
Linux® is the registered trademark of Linus Torvalds in the U.S. and other countries.
Mac OS is a trademark of Apple Inc., registered in the U.S. and other countries.
Microsoft, Windows, and Windows Vista are either registered trademarks or trademarks of the Microsoft Corporation in the United States and/or other countries.